

SETUP & OPERATION MANUAL

FEATURES & SPECIFICATIONS

- Rotating & oscillating effect ensures exceptional finishing results.
- Precision ground cast iron table.
- On-board side mounted spindle storage.
- Tilting table for sanding beveled parts.
- 2" diameter dust outlet with 2" to 4" adapter fitting included.
- 5 interchangeable spindle assemblies: 1/4", 1/2", 5/8", 1 1/2", 2" dia. with 100 grit sand paper.
- 1 1/2" & 2" spindles come with rubber drums.
- Includes 4 table inserts to accommodate different spindle sizes.

OSCILLATIONS PER MINUTE

29

LENGTH OF OSCILLATION

15/16" (24 mm)

TABLE SIZE

14 1/2" x 14 1/2" (368 x 368 mm)

TABLE TILT

0° - 45°

TABLE HEIGHT FROM BOTTOM OF BASE

18 5/16" (465 mm)

SPINDLE SIZES

1/4" TO 2" (6.2 TO 50.8 mm)

DUST CHUTE OUTLET

2" (50.8 mm)

SPINDLE SPEED

1720 RPM

BASE DIMENSIONS (L x W)

14 1/2" x 14 1/2" (368 x 368 mm)

MOTOR

1/2 HP, 110 V, 7.5 A

WEIGHT

81 LBS (37 kg)

OSCILLATING SPINDLE SANDER



MODEL #15-220





GENERAL® INTERNATIONAL

8360 Champ-d'Eau, Montreal (Quebec) Canada H1P 1Y3
Telephone (514) 326-1161 • Fax (514) 326-5555
www.general.ca

THANK YOU for choosing this General® International model 15-220 oscillating spindle sander. This machine has been carefully tested and inspected before shipment and if properly used and maintained, will provide you with years of reliable service. To ensure optimum performance and trouble-free operation, and to get the most from your investment, please take the time to read this manual before assembling, installing and operating the unit.

The manual's purpose is to familiarize you with the safe operation, basic function, and features of this oscillating spindle sander as well as the set-up, maintenance and identification of its parts and components. This manual is not intended as a substitute for formal woodworking instruction, nor to offer the user instruction in the craft of woodworking. If you are not sure about the safety of performing a certain operation or procedure, do not proceed until you can confirm, from knowledgeable and qualified sources, that it is safe to do so.

Once you've read through these instructions, keep this manual handy for future reference.

GENERAL ® INTERNATIONAL WARRANTY

All component parts of General® International machinery are carefully tested and inspected during all stages of production, and each machine is thoroughly inspected upon completion of assembly. Because of our commitment to quality and customer satisfaction, General® International agrees to repair or replace, within a period of 24 months from date of purchase, any genuine part or parts which, upon examination, prove to be defective in workmanship or material. In order to obtain this warranty, all defective parts must be returned freight pre-paid to General® International Mfg. Co., Ltd. Repairs attempted without our written authorization will void this warranty.

Disclaimer: The information and specifications in this manual pertain to the unit as it was supplied from the factory at the time of printing. Because we are committed to making constant improvements, General® International reserves the right to make changes to components, parts or features of this unit as deemed necessary, without prior notice and without obligation to install any such changes on previously delivered units. Reasonable care is taken at the factory to ensure that the specifications and information in this manual corresponds with that of the unit with which it was supplied. However, special orders and "after

factory" modifications may render some or all information in this manual inapplicable to your machine. Further, as several generations of this oscillating spindle sander and several versions of this manual may be in circulation, if you own an earlier or later version of this unit, this manual may not depict your machine exactly. If you have any doubts or questions contact your retailer or our support line with the model and serial number of your unit for clarification.

Rules for Safe Operation

To help ensure safe operation, please take a moment to learn the machine's applications and limitations, as well as potential hazards. General International disclaims any real or implied warranty and hold itself harmless for any injury that may result from the improper use of its equipment.

1. Do not operate this sander when tired, distracted or under the effects of drugs, alcohol or any medication that impairs reflexes or alertness.
2. Keep the work area well lit, clean and free of debris.
3. Stay alert! Give your work your undivided attention. Even a momentary distraction can lead to serious injury.
4. Do not wear loose clothing, gloves, bracelets, necklaces, or other jewelry. Wear face, eye, ear, respiratory and body protection devices. Wear protective hair covering to contain long hair and wear non-slip footwear.
5. Keep hands well away from the spindle and all moving parts. Do not clear chips and sawdust away with hands. Use a brush.
6. Fine particulate dust is a carcinogen that can be hazardous to health. Always work in a well ventilated area and whenever possible use a dust collector to minimize health hazards.
7. Be sure the spindle has achieved full operating speed before beginning to sand.
8. Be aware of the direction of the spindle rotation before feeding the workpiece and always feed the workpiece against the rotation.
9. Do not force the spindle. It will perform better and safer at the rate for which it was designed.
10. Keep children and shop visitors at a safe distance when the unit is running – do not permit them to operate the machine.
11. Do not operate with a damaged spindle or with a damaged or torn sanding sleeve.
12. Be sure the sanding spindle is securely installed in the machine before starting the machine.
13. Never leave the machine unattended while running or with the power on.
14. Do not sand without a table insert in place. If an insert must be removed for maintenance or spindle changes make sure it is properly re-installed before re-starting the machine.
15. Hold the workpiece firmly against the table and use suitable support if the workpiece does not have a flat surface.
16. Never stand on or lean against this machine. Serious injury could occur if the sander is tipped over or if the sanding spindle is unintentionally contacted.
17. Use only recommended parts and accessories. The use of parts or accessories NOT recommended by General@ International may result in a risk of injury.
18. Make sure the machine is properly grounded. If equipped with three-prong plug, it should be plugged into a three-pole electrical receptacle. Never remove the third-prong.
19. Always disconnect the unit from the power source before changing accessories such as sanding spindles or sleeves or before performing any maintenance and adjustments or if the machine will be left unattended.
20. Make sure that switch is in the "Off" position before plugging in to a power source.
21. Be sure that all adjustment tools, wrenches or other clutter are removed from the machine and safely stored before turning on the unit.
22. Avoid working from awkward or off balance positions. Do not overreach and always keep both feet firmly on the floor.
23. Do not use this spindle sander for other than its intended use. If used for other purposes, GENERAL@ INTERNATIONAL disclaims any real or implied warranty and holds itself harmless for any injury, which may result from that use.

ELECTRICAL REQUIREMENTS



Before connecting the machine to the power source, verify that the voltage of your power supply corresponds with the voltage specified on the motor I.D. nameplate. A power source with greater voltage than needed can result in serious injury to the user as well as damage to the machine. If in doubt, contact a qualified electrician before connecting to the power source.



In all cases, make certain the receptacle is properly grounded. If you are not sure, have a qualified electrician check the receptacle.



This tool is for indoor use only. Do not expose to rain or use in damp locations.

GROUNDING INSTRUCTIONS

In the event of an electrical malfunction or short circuit, grounding reduces the risk of electric shock to. This motor of this machine is wired for 110V single phase operation and is equipped with a 3-conductor cord and a 3-prong grounded plug to fit a grounded type socket. Do not remove the the 3rd prong (grounding pin) to make it fit into an old 2-hole wall socket. If an adaptor plug is used it must be attached to the metal screw of the socket. The wall socket must be properly installed and grounded. Note: The use of an adaptor plug is illegal in some areas. Check you local codes.

DO NOT MODIFY THE PLUG PROVIDED.

If it will not fit your receptacle, have the proper receptacle installed by a qualified electrician.

CHECK with a qualified electrician or service person if you do not completely understand these grounding instructions, or if you are not sure the tool is properly grounded.

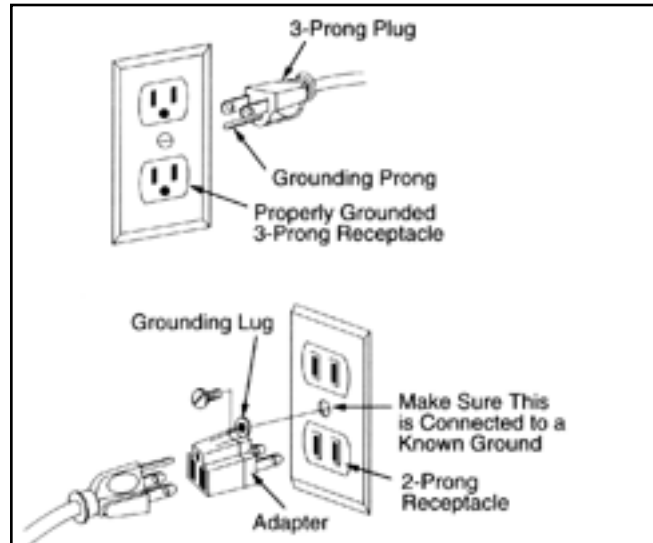

This tool must be grounded while in use to protect the operator from electrical shock.

EXTENSION CORDS

USE ONLY 3-WIRE EXTENSION CORDS THAT HAVE 3-PRONG GROUNDING PLUGS AND 3-POLE RECEPTACLES THAT ACCEPT THE TOOL'S PLUG. REPAIR OR REPLACE DAMAGED OR WORN CORD IMMEDIATELY.

If you find it necessary to use an extension cord with your machine make sure the cord rating is suitable for the amperage listed on the motor I.D. plate. An undersized cord will cause a drop in line voltage resulting in loss of power and overheating. The accompanying chart shows the correct size extension cord to be used based on cord length and motor I.D. plate amp rating. If in doubt, use the next heavier gauge. The smaller the number the heavier the gauge.

AMPERES (AMPS)	EXTENSION CORD LENGTH					
	25 feet	50 feet	75 feet	100 feet	150 feet	200 feet
< 5	16	16	16	14	12	12
5 to 8	16	16	14	12	10	NR
8 to 12	14	14	12	10	NR	NR
12 to 15	12	12	10	10	NR	NR
15 to 20	10	10	10	NR	NR	NR
21 to 30	10	NR	NR	NR	NR	NR

* Based on limiting the line voltage drop to 5V at 150% of the rated amperes.

NR = Not Recommended



VERTICAL OSCILLATING SPINDLE SANDER 15-220

IDENTIFICATION OF MAIN PARTS AND COMPONENTS

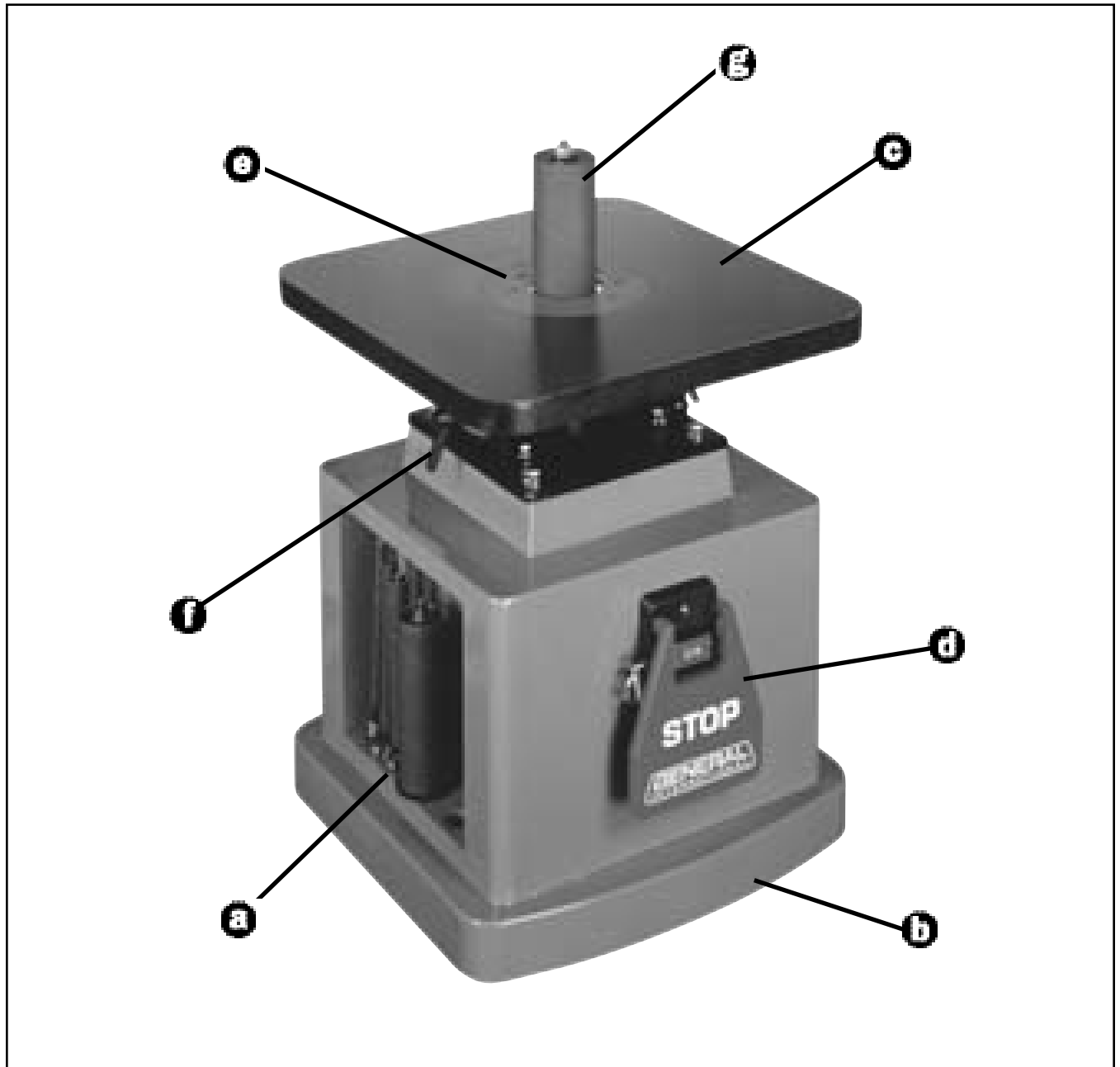

- a** ACCESSORY STORAGE
- b** BASE
- c** CAST-IRON TABLE
- d** SWITCH ASSEMBLY

- e** TABLE INSERT
- f** TABLE TILT LOCK LEVER
- g** SANDING SPINDLE

UNPACKING AND SET-UP

SET UP SAFETY



⚠ Serious personal injury could occur if you connect the machine to the power source before you have completed the set up process. **DO NOT** connect the machine to the power source until instructed to do so.



⚠ The MODEL 15-220M1 is a heavy machine (81 lbs shipping weight-37kg). Do not over-exert. Arrange to have help nearby and ready for unpacking and set up.

ADDITIONAL REQUIREMENTS FOR SET UP

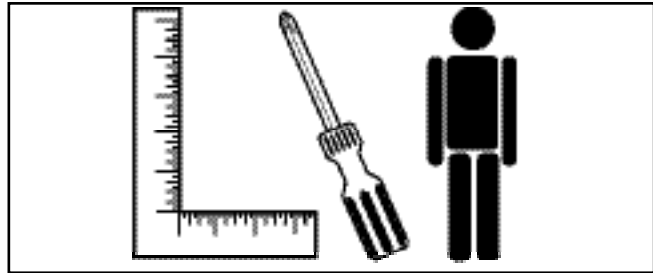

- Machinists square
- Medium Phillips Screwdriver
- An extra person for help lifting

UNPACKING

Carefully unpack and remove the unit and its components from its shipping container and check for missing or damaged items as per the list of contents below.

NOTE: Please report any damaged or missing items to your **GENERAL® INTERNATIONAL** distributor immediately.

LIST OF CONTENTS

Separate and verify that all parts are in your accessories hardware bags.

	QTY
Ⓐ MACHINE	1
Ⓑ RED STOP COVER	1
Ⓒ DUST HOSE ADAPTOR 2" TO 4"	1
Ⓓ SANDING SPINDLE HARDWARE	
— Sanding drum spindle assembly 1 1/2"	1
— Sanding drum spindle assembly 2"	1
— Sanding sleeve 5/8"	1
— Sanding sleeve 1/2"	1
— Sanding sleeve 1/4"	1
— Spindle 5/8"	1
— Spindle 1/2"	1
— Spindle 1/4"	1
Ⓔ TABLE INSERT 2" (oblong)	1
Ⓕ TABLE INSERT 3/4" (oblong)	1
Ⓖ TABLE INSERT 3/4" (round -*Mounted on the machine)	1
Ⓗ TABLE INSERT 2" (round)	1
Ⓘ 10-12 mm WRENCH	1
Ⓚ 14-17 mm WRENCH	2



CLEAN UP



Be sure to work in a well ventilated area for the entire clean up process.



Before starting the clean up process make sure the machine is not plugged into a power source. Failure to comply may lead injury or cause damage to the machine.

All unpainted surfaces are covered with a protective coating that prevents rust from forming during shipping and storage. Peel off the plastic cover from the table and remove this protective coating by rubbing with a rag dipped in kerosene, mineral spirits or paint thinner. (Dispose of potentially flammable solvent-soaked rags according to manufacturer's safety recommendations.)

A putty knife, held flat to avoid scratching the surface, may also be used to scrape off the coating followed by clean-up with solvent. Avoid rubbing the machine's painted surfaces, as many solvent-based products will remove paint.

For optimum performance from your machine, make sure you clean all metal surfaces of the spindles with a mild solvent or kerosene.

To prevent rust, apply a light coating of paste wax or regular applications of General International "Top Saver" item # GC-010 or similar after-market protectants to the table surface.



ASSEMBLY INSTRUCTIONS



The unit should be installed on a flat, sturdy and stable surface able to support the weight of the machine.



Never install the machine over the edge of a table or workbench.



Never lift the machine by the table; hold and lift from the insets on the cabinet.

Make sure that the switch is in "OFF" position and that the power cord is unplugged & install the red stop switch cover plate.

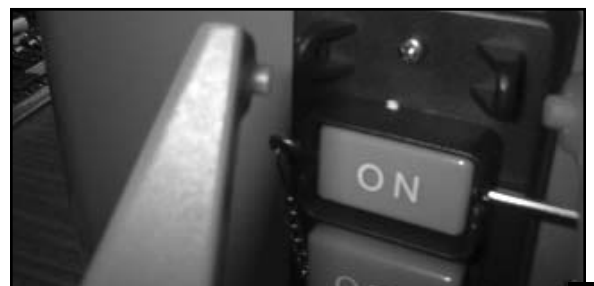

INSTALL THE SANDING SLEEVES ONTO THEIR CORRESPONDING SPINDLES



Step 1

For 1/4, 1/2, & 5/8 spindles loosen the screw on the bracket clamp (1) at the bottom of the spindle.



Step 2

Slide the sanding sleeve onto the spindle completely. **Note: the sleeve should slide under the bracket clamp as shown.** Re-tighten the screw on the bracket clamp to secure the sleeve in place.

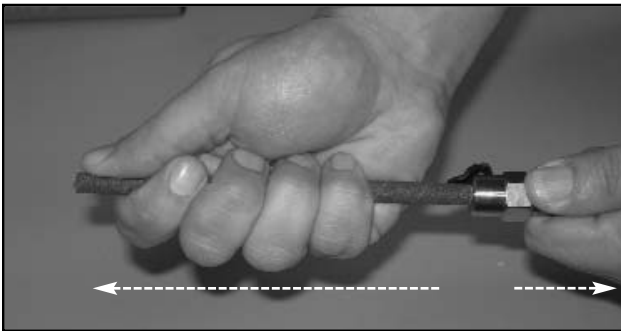

Step 3

Double check that the sleeve is now on the spindle securely by pulling on the sleeve to make sure it does not slide off the spindle.

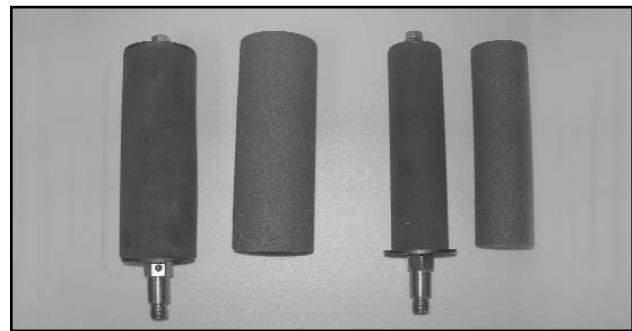

Step 4

For the 1 1/2" and 2" spindles slide the sleeve onto the spindle.

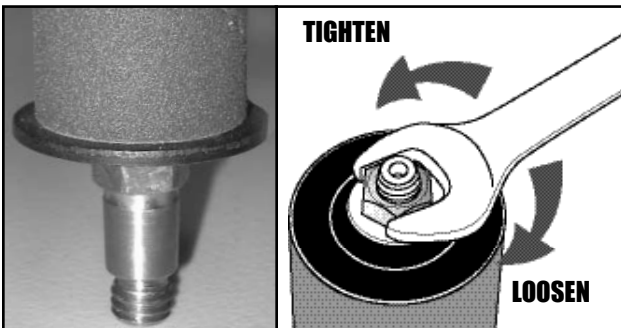

Step 5

Using the supplied 12 mm wrench tighten the nut on the top of the spindle by turning counter clockwise (reverse thread).

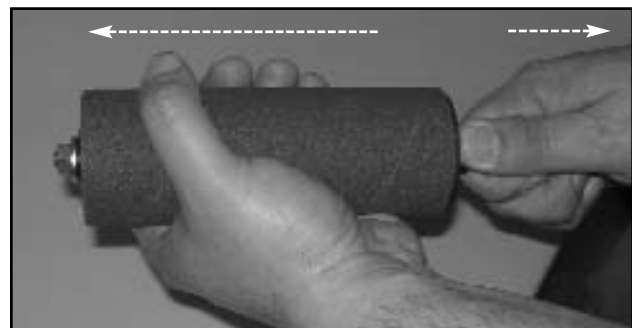

Step 6

Double check that the sleeve is now on the spindle securely by pulling on the sleeve to make sure it does not slide off the rubber drum. If the sleeve slides on the drum, continue tightening the nut (**step 5**) in 1/2 turn increments as needed.

ACCESSORY STORAGE



SPINDLES

Place the drums into their storage space on the right side of the machine.

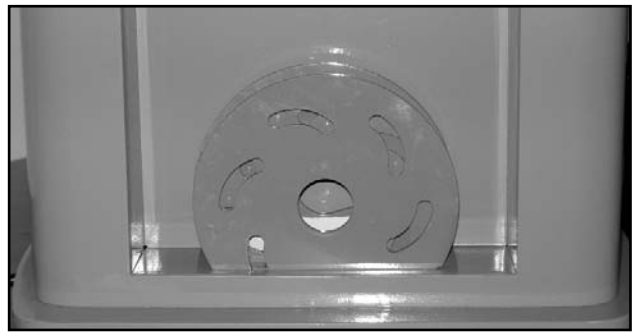

TABLE INSERT PLATES

Store the table insert plates in the storage slots on the left side of the machine.

INSTALLING SPINDLES ON THE MACHINE

Note: Reverse threads are used to attach the spindle to the machine.

Make sure that the switch is in "OFF" position and that the power cord is unplugged.



If installed, remove the table insert to allow better access the spindle seat.

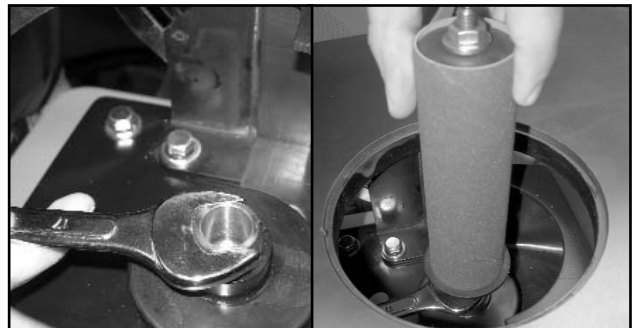

Step 1

Select the desired spindle and while holding the spindle seat in place with a 17 mm wrench, screw the threaded end into the spindle seat counter clockwise (reverse threads) until hand tight.

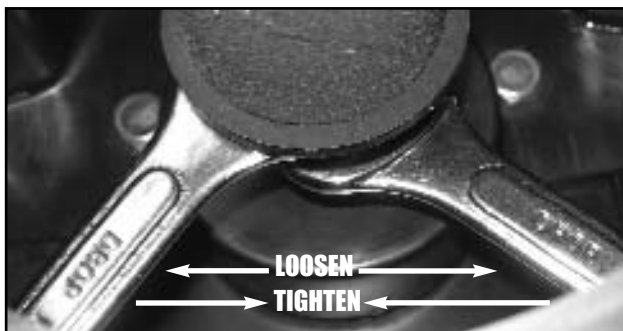

Step 2

Using the two 17 mm wrenches tighten the spindle no more than another 1/2 turn.

NOTE: Do not overtighten the spindle in the seat or it may be very difficult to take off later.



BEFORE STARTING THE MACHINE:

- Make sure the spindle is securely installed onto the arbor.
- Make sure that the corresponding table insert is installed. See the accompanying SELECTION GUIDE (page 10) to select the correct INSERT TABLE for the spindle being used.

SELECTION GUIDE FOR TABLE INSERTS

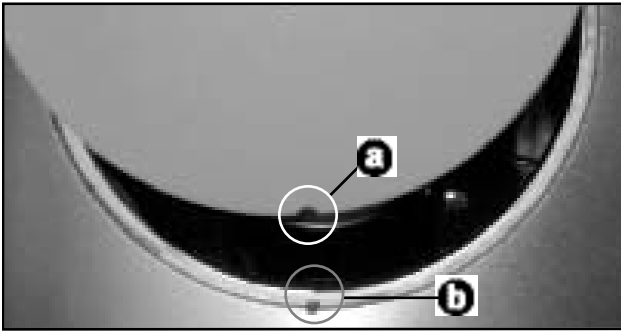

This machine is supplied with 5 spindles, and four table inserts. The spindle diameters range from 1/4" to 2". When changing spindles, the table insert will need to be changed to the matching size. Each plate has notch (**a**) to fit the alignment pin (**b**) in the table to ensure that it is properly fitted and installed in the table opening.

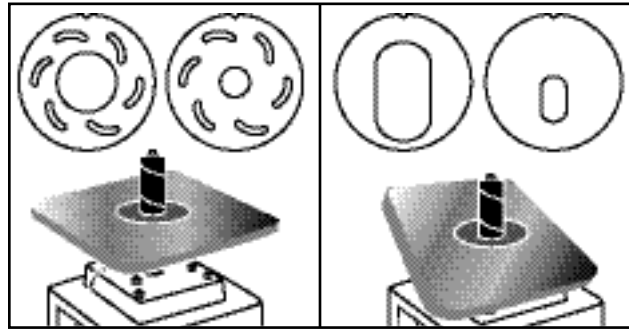

There are 2 insert plates with oblong openings and 2 with round openings. The oblong insert plates are used when the table is tilted for bevel sanding.



FAILURE TO USE THE PROPER INSERT WITH THE CORRESPONDING SPINDLE MAY RESULT IN INJURY AND/OR DAMAGE TO THE MACHINE OR THE WORKPIECE.

The following chart explains which inserts can be used for different diameter spindles.

SPINDLE DIAMETER	TABLE INSERT (OPENING SHAPE/SIZE)
1/4"	#86 (ROUND) & #87 (OBLONG) -SMALL
1/2"	#86 (ROUND) & #87 (OBLONG) -SMALL
5/8"	#86 (ROUND) & #87 (OBLONG) -SMALL
1-1/2"	#85 (ROUND) & #84 (OBLONG) -LARGE
2"	#85 (ROUND) & #84 (OBLONG) -LARGE

RECOMMENDED ADJUSTMENTS

SETUP FOR 90° SANDING

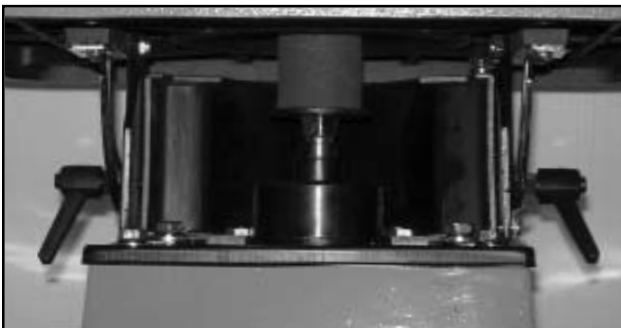

Step 1

Loosen both locking levers, position the table at 0° and re-tighten the locking levers.

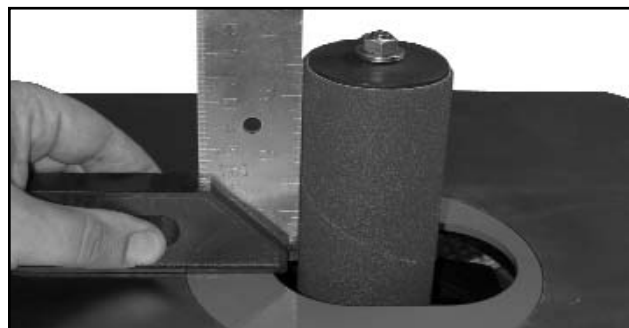

Step 2

With a spindle installed, place a square on the table. Rest the long section of the square against the sanding spindle. The square should be flat against the table and the spindle from all four sides.

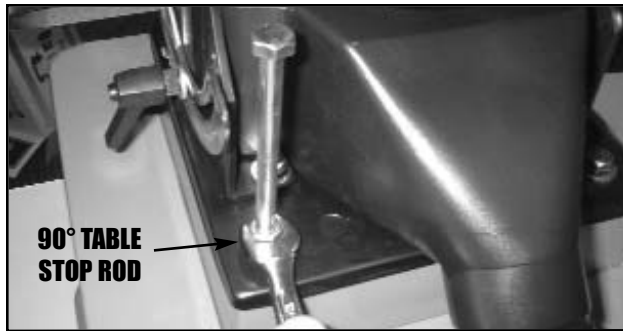

Step 3

If the table needs adjustment loosen both lock levers and readjust the table position until the square is flat against the table and the sanding drum. To allow for more or less rear tilt adjust the table stop rod as needed.

Step 5

Once the table has been adjusted and locked in place at 90° adjust the 90° table stop rod to butt against the underside of the table allowing you to return to 90° repeatedly without further adjustments.

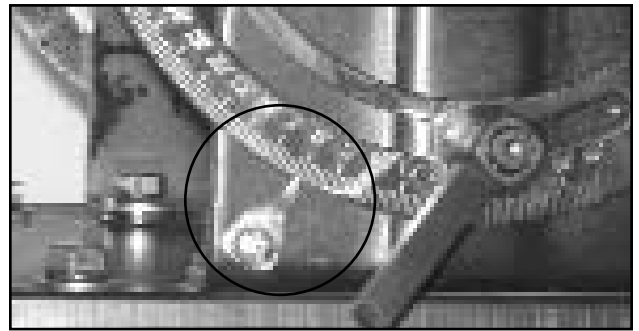

Step 4

Make sure the pointer reads 0°. If the pointer needs to be adjusted loosen the screw and adjust to the correct position.

SETUP FOR BEVEL SANDING

1. Make sure the correct oblong opening table insert is in place. See the accompanying SELECTION GUIDE (page 10) to select the correct TABLE INSERT for the spindle being used.
2. Loosen both locking levers and tilt the table until the pointer is at the desired angle.
3. Hold the table in place and tighten both locking levers.

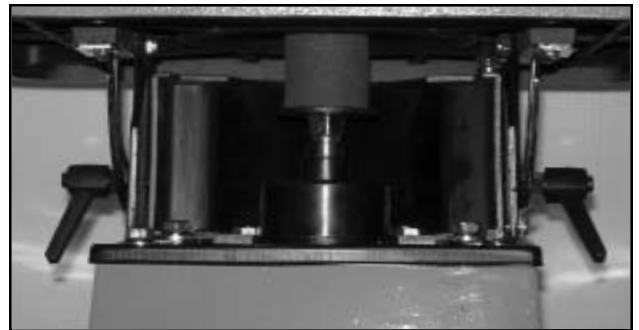

CHANGING SANDING SLEEVES

Make sure that the switch is in "OFF" position and that the power cord is unplugged.

Note: Installing or changing sanding sleeves is best performed with the spindle removed from the machine.

Refer to page 8 - "Installing the sanding sleeves" for step by step instructions.

REPLACEMENT SANDING SLEEVES

Replacement sleeves can be purchased in varying grits (depending on availability) from any local tool or abrasives dealer in the following sizes:

- 1/4" DIAMETER X 6 " LONG
- 1/2" DIAMETER X 6 " LONG
- 5/8" DIAMETER X 6 " LONG
- 1-1/2" DIAMETER X 5 1/2 " LONG
- 2" DIAMETER X 5.5" LONG

CONNECT TO A DUST COLLECTOR



Before sanding connect the machine to a dust collection system.



Always turn on the dust collector before starting the sander and always stop the sander before turning off the dust collector.

- There is a 2" diameter dust outlet on the rear of the machine allowing for the connection to a dust collector (not included).
- A 2" TO 4" DUST HOSE ADAPTOR is also included to facilitate (if needed) connection to a standard 4" dust collection hose.
- Be sure to use appropriate size hose and fittings (not included), and check that all connections are sealed tightly to minimize airborne dust.
- If you do not already own a dust collection system consider contacting your GENERAL® INTERNATIONAL distributor for information on our complete line of dust collection systems or visit our Web Site at: www.general.ca



OPERATING INSTRUCTIONS

BASIC FUNCTIONS OF THIS MACHINE

This machine has been designed for sanding or polishing round or curved surfaces on wood, plastic, or metal materials. It is ideal for use in smaller woodworking projects in a hobbyist/home shop environment. This machine is not designed with a continuous duty rating or for industrial applications.

CONNECTING TO A POWER SOURCE

Plug the machine into a proper receptacle – before connecting to the power source make sure that the switch is in the “off” position and that the power supply is of the same type as that stamped on the I.D. nameplate of the motor. Running on low voltage will damage the motor.



To avoid risk of shock or fire do not operate the unit with a damaged power cord or plug. Replace damaged cord or plug immediately.

ON/OFF SWITCH & SAFETY PIN

The switch assembly is equipped with a lock-out safety pin. When the pin is installed through the green “on” button, the machine cannot be started.

To start the machine, lift the red stop switch panel and remove the lock-out pin. Lower the stop panel and push the green “ON” button. Wait for the spindle to reach full speed before sanding.

To stop the machine, push on the RED “STOP” panel and wait for the spindle to come to a complete stop.

When you have finished using the machine be sure to re-install the lock-out pin and unplug the machine from the power source.



BASIC OPERATIONS



Before operating this machine, make sure you have read this manual attentively! Failure to read and understand the instructions, warnings and safety guidelines provided in this manual may lead to serious injury and / or damage to machine or the workpiece.



Be sure the sanding spindle is securely installed in the machine.



Make sure the table tilt locking levers are secured and that the table is locked in place at the desired angle or tilt.



Make sure the machine is installed on a flat, sturdy and stable surface able to support the weight of the machine and the workpiece to be sanded.

1. Select and install a spindle that is smaller than the curve to be sanded.
2. Use an appropriate table insert plate that comes closest to the spindle without touching it.
3. Make sure that spindle is properly installed in the spindle seat. With the supplied wrenches tighten the nut slightly beyond hand-tight.

NOTE: Spindle threads are reversed. Turn Clockwise to loosen and counter clockwise to tighten.

NOTE: Never over tighten; it may be difficult to remove the spindle later.

4. When table is set at a 90° angle, sanding may be done from any corner, or location on the table.
5. When the table is positioned at any angle other than 90°, sanding should only be performed with the workpiece positioned below the centre point of the table (photo)
6. Make sure the table tilt locking levers are secured and that the table is locked in place at the desired angle or tilt.
7. Always loosen both table tilt locking levers before changing the angle position of the table. Never force the table. If it does not tilt easily it may be that the locking levers may still be engaged.
8. Hold the workpiece firmly and work from a stable standing position.
9. To achieve the best finish results and to ensure maximum sanding sleeve life, slowly move the workpiece back and forth across the entire surface of the sanding spindle.

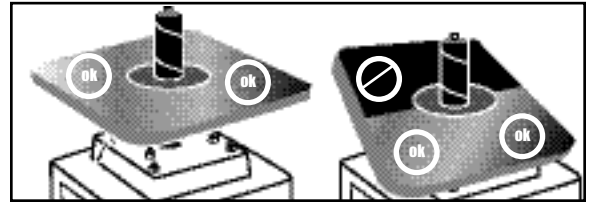

MAINTENANCE

Make sure the switch is in the OFF position and unplug the unit from the power source before performing any maintenance.

- All bearings are sealed and permanently lubricated. No further lubrication is needed.
- Periodically inspect all hardware, fittings and fasteners that may have loosened due to vibration – re-tighten as needed.
- To minimize airborne dust particles periodically inspect all dust collection fittings – re-tighten as needed.
- Inspect the ON/OFF SWITCH for damage before each use.
- Keep the machine CLEAN and FREE OF DUST to help dissipate heat.
- Check and if necessary replace all damaged TABLE INSERTS, SPINDLES or SANDING SLEEVES
- Periodically inspect the power cord and plug for damage. If necessary replace the power cord and the plug at the first signs of visible damage.
- Use only recommended parts and accessories. The use of parts or accessories NOT recommended by General International may result in a risk of injury or damage to the machine.

RECOMMENDED OPTIONAL ACCESSORIES FOR YOUR OSCILLATING SPINDLE SANDER

We offer a large variety of products to help you increase productivity, accuracy and safety when using your oscillating spindle sander. Here's a small sampling of accessories available from your local General International dealer.



ITEM #	DESCRIPTION	
15-211A	Sanding Sleeve 1/4" X 6"	40 Grit
15-211B	Sanding Sleeve 1/4" X 6"	60 Grit
15-211C	Sanding Sleeve 1/4" X 6"	80 Grit
15-211D	Sanding Sleeve 1/4" X 6"	100 Grit
15-211E	Sanding Sleeve 1/4" X 6"	120 Grit
15-211F	Sanding Sleeve 1/4" X 6"	150 Grit
15-212A	Sanding Sleeve 1/2" X 6"	40 Grit
15-212B	Sanding Sleeve 1/2" X 6"	60 Grit
15-212C	Sanding Sleeve 1/2" X 6"	80 Grit
15-212D	Sanding Sleeve 1/2" X 6"	100 Grit
15-212E	Sanding Sleeve 1/2" X 6"	120 Grit
15-212F	Sanding Sleeve 1/2" X 6"	150 Grit
15-213A	Sanding Sleeve 5/8" X 6"	40 Grit
15-213B	Sanding Sleeve 5/8" X 6"	60 Grit
15-213C	Sanding Sleeve 5/8" X 6"	80 Grit
15-213D	Sanding Sleeve 5/8" X 6"	100 Grit
15-213E	Sanding Sleeve 5/8" X 6"	120 Grit
15-213F	Sanding Sleeve 5/8" X 6"	150 Grit
15-214A	Sanding Sleeve 1 1/2" X 5 1/2"	40 Grit
15-214B	Sanding Sleeve 1 1/2" X 5 1/2"	60 Grit
15-214C	Sanding Sleeve 1 1/2" X 5 1/2"	80 Grit
15-214D	Sanding Sleeve 1 1/2" X 5 1/2"	100 Grit
15-214E	Sanding Sleeve 1 1/2" X 5 1/2"	120 Grit
15-214F	Sanding Sleeve 1 1/2" X 5 1/2"	150 Grit
15-215A	Sanding Sleeve 2" X 5 1/2"	40 Grit
15-215B	Sanding Sleeve 2" X 5 1/2"	60 Grit
15-215C	Sanding Sleeve 2" X 5 1/2"	80 Grit
15-215D	Sanding Sleeve 2" X 5 1/2"	100 Grit
15-215E	Sanding Sleeve 2" X 5 1/2"	120 Grit
15-215F	Sanding Sleeve 2" X 5 1/2"	150 Grit



**Stand
#15-230**



Dust Collector

We have a wide selection of dust collectors to suit all your shop needs. Dust collectors contribute to a cleaner and more healthful workshop environment.



"TOP SAVER" cleaner #GC-010

All in one, table top rust remover and lubricant. /Reduces friction and prevents binding. / Removes and inhibits rust and corrosion. /Repels dust and moisture.

**PARTS LIST
15-220**

PART NO.	REF. NO.	DESCRIPTION	SPECIFICATION	QTY
15220-01	30201001G	BASE		1
15220-02	30201001A	TOP PLATE		1
15220-03	S1006P1	STRAIN RELIEF		1
15220-04	L0000000	POWER CORD	(W/PLUG)	1
15220-05	S0030622M	PHILLIPS HEAD SCREW	M6 X 1 X 22L	4
15220-06	10107098	RUBBER FOOT		4
15220-07	S0210400	WASHER	1/4" X 19MM	6
15220-08	S0110600M	LOCK NUT	M6X1.0	4
15220-09	S0230300	LOCK WASHER	3/16"	2
15220-10	S0030318	PHILLIPS HEAD SCREW	3/16"-24UNC X 3/4"	2
15220-11	M0000000	MOTOR		1
15220-12	S0430650	KEY	6 X 6 X 50	1
15220 -13	S0040415M	SET SCREW	M4 X 0.7 X 15L	2
15220-14	30202001	WORM GEAR		1
15220-15	S0050610M	SET SCREW	M6 X 1.0 X 10L	2
15220-16	30202002	TRANSMISSION ROD	M8 X 1.25 X 75L	1
15220-17	S0110800M	HEX. NUT	M8 X 1.25	1
15220-18	30202003	CONNECTING ROD		2
15220-19	S0210400	WASHER	1/4" X 19MM	4
15220-20	S012500M	HEX NUT	M5	2
15220-21	C1106804	BEARING	6804ZZ	1
15220-22	30202004	SPINDLE SEAT		1
15220-23	CL106006	BEARING	6006ZZ	1
15220-24	S0520059	RETAINING RING- C TYPE		1
15220-25	30202005	CONNECTING ROD NUT		4
15220-26	S0050506M	SET SCREW	M5 X 0.8 X 6L	2
15220-27	S05ETW04	RETAINING RING-E TYPE		2
15220-28	30202020	CONNECTING SPINDLE		1
15220-29	30202006P	WHEEL SEAT		1
15220-30	30202007P	WHEEL		1
15220-31	S0010615M	SET SCREW	M6 X 1.0 X 10L	4
15220-32	30202008P	WHEEL ARBOR		1
15220-33	30204010	ARBOR COVER		2
15220-34	S0230400	LOCK WASHER	1/4"	4
15220-35	S0400415	KEY	4 X 4 X 15	1
15220-36	CL106001	BEARING	6001ZZ	2
15220-37	S0521200	RETAINING RING C-TYPE	STW-12	2
15220-38	S0530028	RETAINING RING C-TYPE	R-28	2
15220-39	S0230506	LOCK WASHER	5/16"	11
15220-40	S0210500C	FLAT WASHER	5/16" X 18 X 2T	11
15220-41	30202009	OIL CAP		1
15220-42	30202014	REAR OIL CAP		1
15220-43	S0030304	PHILLIPS HEAD SCREW	3/16"-24UNC X 1/4"	2
15220-44	30203001	MAIN CASTING		1
15220-45	30203003	L BRACKET	(RIGHT)	1
15220-46	30203003A	L BRACKET	(LEFT)	1
15220-47	S0020825M	CAP SCREW	M8 X 1.25 X 20L	11
15220-48	30300028	90° TABLE STOP ROD	M8 X 1.25 X 110L	1
15220-49	S0110600	HEX NUT	M8	1
15220-50	40501011	TABLE TILT GUIDE BRACKET WITH SCALE (RIGHT)		1

**PARTS LIST
15-220**

PART NO.	REF. NO.	DESCRIPTION	SPECIFICATION	QTY
15220-51	40501011A	TABLE TILT GUIDE BRACKET	(LEFT)	1
15220-52	30204013G	LOCKING LEVER		2
15220-53	S0010516M	PHILLIPS HEAD SCREW		4
15220-54	S0050606M	SET SCREW	M6 X 1.0 X 6L	1
15220-55	10102022	ANGLE POINTER		1
15220-56	S0220400	SPROCKET WASHER	1/4"	1
15220-57	S0030510M	PHILLIPS HEAD SCREW	M5 X 0.8-10L	1
15220-58	30203005	DUST PORT		1
15220-60	30203006	SPINDLE	22 X 119	1
15220-61	30203007	COVER		1
15220-62	S0030508M	SET SCREW	M5 X 0.8-8L	2
15220-63	S0520028	SNAP RING		1
15220-64	30203008	5/8" SPINDLE		2
15220-64A	30203008G	5/8" SPINDLE		1
15220-65	S0400550	KEY	5 X 5 X 50	1
15220-66	30203015	DRUM	2"	1
15220-67	30203014	DRUM	1-1/2"	1
15220-68	30203017	1/2" SPINDLE		1
15220-69	30203018	1/4" SPINDLE		1
15220-70	30203019	1/2" CLAMP		1
15220-71*	SEE LIST ON PG. 14 FOR OPTIONAL/REPLACEMENT SANDING SLEEVES			
15220-72*	SEE LIST ON PG. 14 FOR OPTIONAL/REPLACEMENT SANDING SLEEVES			
15220-73*	SEE LIST ON PG. 14 FOR OPTIONAL/REPLACEMENT SANDING SLEEVES			
15220-74*	SEE LIST ON PG. 14 FOR OPTIONAL/REPLACEMENT SANDING SLEEVES			
15220-75*	SEE LIST ON PG. 14 FOR OPTIONAL/REPLACEMENT SANDING SLEEVES			
15220-76	30203019A	5/8" CLAMP		1
15220-77	30203019B	1/4" CLAMP		1
15220-78	30204001	MAIN TABLE		1
15220-79	20301002	LOWER FOLLOWER PLATE	1-1/2" & 2"	2
15220-80	20801002	UPPER FOLLOWER PLATE	1-1/2"	1
15220-81	20301044	UPPER FOLLOWER PLATE	2"	1
15220-82	S02 10500	WASHER	5/16" X16	2
15220-83	S0110500	5/16" NUT (LH)		2
15220-84	30204003	TABLE INSERT (OBLONG)	2"	1
15220-85	30204004	TABLE INSERT (ROUND)	2"	1
15220-86	30204005	TABLE INSERT (ROUND)	3/4"	1
15220-87	30204006	TABLE INSERT (OBLONG)	3/4"	1
15220-88	S0310312	ALIGNMENT SPRING PIN	3 X 12M/M	1
15220-89	30201003	COMBINATION WRENCH	14/17MM (NOT SHOWN)	2
15220-90	10105091	COMBINATION WRENCH	10/12 (NOT SHOWN)	1
15220-91	J8010004	WARNING LABEL	(NOT SHOWN)	1
15220-92	J2091001	I.D LABEL	(NOT SHOWN)	1
15220-93	WG000001	SWITCH ASSEMBLY W/ COVER PLATE		1
15220-94		RED STOP SWITCH COVER PLATE		1
15220-95	WG000002	SWITCH BOX		1
15220-96	WG000003	SAFETY LOCK-OUT PIN W/CHAIN		1
15220-97		2" TO 4" DUST HOSE ADAPTOR		1

15-220

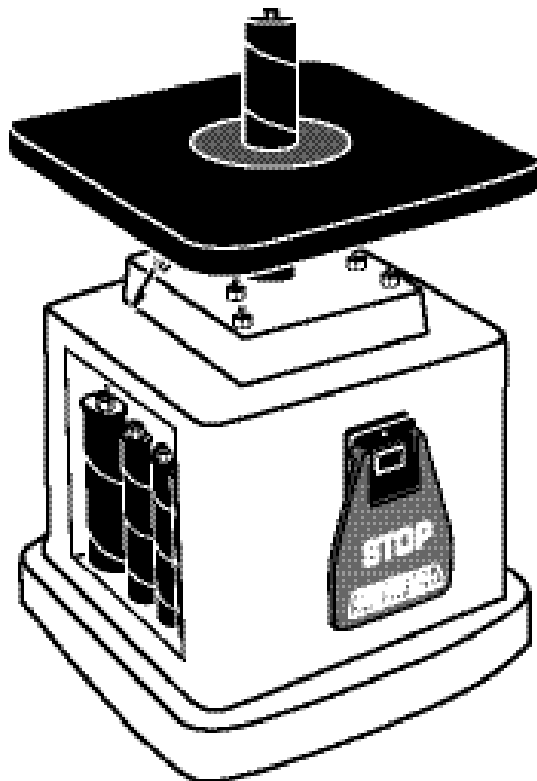

**8360 Champ-d'Eau, Montreal (Quebec)
Canada H1P 1Y3**

Tel.: (514) 326-1161
Fax : (514) 326-5565 Parts & Service
Fax : (514) 326-5555 Order Desk
orderdesk@general.ca
www.general.ca

IMPORTANT: When ordering replacement parts, always give the model number, serial number of the machine and part number. Also a brief description of each item and quantity desired.